

January, 2010

INDUSTRIAL APPLICATIONS OF FISONIC™ DEVICES

V. Fisenko, PhD¹, R. Kremer² and I. Oliker, PhD, PE³



FISONIC CORP.
143 West 72nd Street • New York, NY 10023 • 212-732-3777
www.fisonic.us

Theoretical Basis of Fisonic™ Devices

Fisonic Devices (FDs) are heat exchangers, pumps and mixers with patented optimized internal geometry. The original theory of Fisonic devices was developed by Professor Fisenko by addressing safety problems of the Russian nuclear submarines during the disruption of the air tightness of reactor cavity. In the open press some results of his work were published in the end of the 70's and were summarized in his first monograph (Ref 1). Based on this work during the following years Dr. Fisenko developed the application of the FD for various industries ranging from nuclear power (Ref.16,17) to food technologies (Ref.18,19). This work was partially summarized in the 1987 in his second monograph (Ref. 2).

The diagram of a FD is presented in Figure 1. At this design the injected water enters the mixing chamber with high velocity in parallel with the velocity of the working stream. The injected water is typically supplied through a narrow circumferential channel surrounding the working nozzle. The mixing chamber has typically a conical shape. **The FDs operate with high expansion and small compression ratios. The discharge pressure in the FDs is typically higher than the pressure of the working and injected streams.**

The principal differences between FDs and conventional Jet Apparatus are as follows. The Jet Apparatus (JA) is widely used in various industries and includes Venturi desuperheaters, steam ejectors, jet exhausters and compressors, jet eductors and jet vacuum pumps. The JA consists of three principal parts: a converging (working) nozzle surrounded by a suction chamber, mixing nozzle and a diffuser (Figure 2). The working (motive) and injected (entrained) streams enter into the mixing nozzle where the velocities are equalized and the pressure of the mixture is increased. From the mixing nozzle the combined stream enters the diffuser where the pressure is further increased.

-
1. Professor Fisenko is the chief scientist of the Mechanical Engineering Institute of the Russian Academy of Science, and Founding Partner of Fisonic Corp.
 2. R. Kremer is Founding Partner of Fisonic Corp. Developer & Licensor of Fisonic.
 3. Dr. I.Olikier is the Principal of Joseph Technology Corporation involved in application of Fisonic devices in various industries.

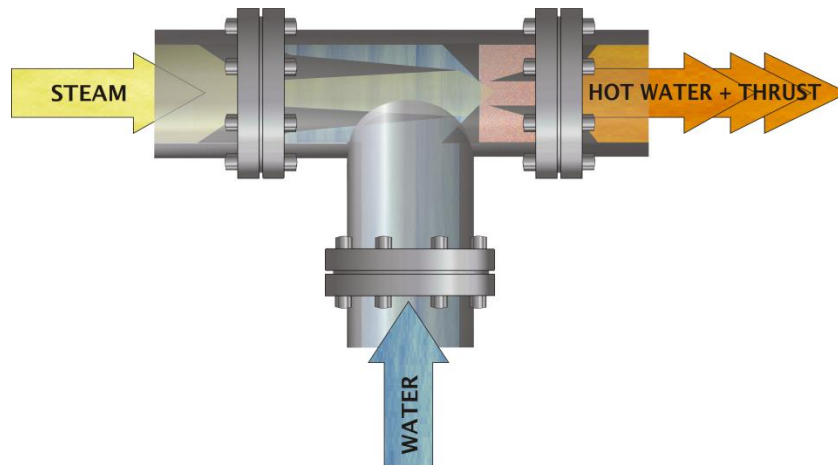

Figure 1. The Fisonic Device Diagram

From the mixing nozzle the combined stream enters the diffuser where the pressure is further increased. The diffuser is so shaped that it gradually reduces the velocity and converts the energy to the discharge pressure with as little loss as possible. The JA transforms the kinetic energy of the working stream to the injected stream by direct contact without consumption of mechanical energy. **The JA's operate with high expansion and moderate or high compression ratios.**

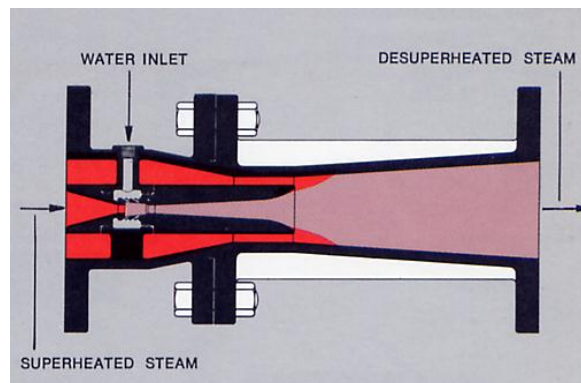

Figure 2. Typical Jet Steam Desuperheating Apparatus

In the JA's during the interaction of two streams with various velocities an increase in entropy of the mixed stream takes place (as compared with an invertible mixing), resulting in the reduction of the pressure of the discharged stream. Therefore, **typically the discharge pressure of the JA is higher than the pressure of the injected stream but lower than the pressure of the working stream.**

Dr. Fisenko has demonstrated that uniform two-phase flows have more compressibility than the flows of pure gases. Hence the possibilities of the more effective conversion of thermal energy into the mechanical work in uniform two-phase mixtures especially in the transonic or supersonic modes. The optimized internal geometry of the FD causes the working and the injected streams to mix and accelerate, creating transonic conditions and converting the minute fractions of the streams thermal energy to physical thrust (pump head) with the discharge pressure higher than the pressure of the mixing streams. The main reason behind this phenomenon is the high compressibility of homogeneous two-phase flows. The sonic speed in such systems is much lower than the sonic speed in liquids and in gases. As one can see from Figure 3 the minimum sonic velocity takes place at the volumetric ratio of the streams of 0.5. The important feature of the FD is also the independence of the discharge flow from the changing parameters of the customer system (like back pressure).

Where:

S= sonic velocity, m/s.

β = ratio of volumetric gas to liquid plus gas composition ($\beta = \frac{V_g}{V_g + V_{ld}}$)

From Figure 3 one can see that when there is no liquid - the ratio β equals one, if there is no gas - the ratio β equals zero. When there is 50% liquid and 50% gas (two phase flow) – the ratio β is equal 0.5 and the sonic velocity is much lower than in gases and liquids.

Water, S, m/s

Gas, S, m/s

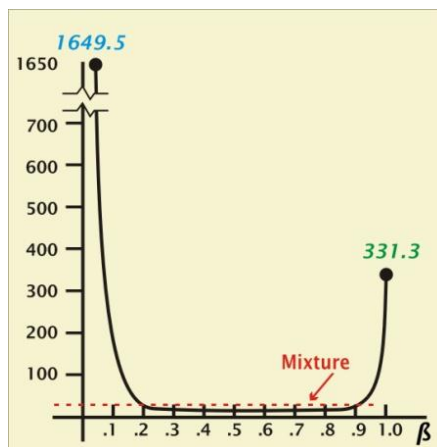

Figure 3. The Dependence of Sonic Speed on Volumetric Ratio of Streams

The equation of sonic speed is as follows:

$$S^2 = \frac{kP}{\rho} \dots\dots\dots(1)$$

Where:

k = isentropic exponent, equal to the ratio of specific heats; P = pressure; ρ = density of the medium.

For determining the isentropic exponent, Prof. Fisenko developed the following equation:

$$\frac{k_g(k+1) - 2k}{k_g - 1} = k\beta \left[1 + \left(\frac{1}{\beta} - 1 \right)^2 \right] - 2 \left(\frac{1}{\beta} - 1 \right) \left(\frac{1}{\varepsilon} - 1 \right) \dots\dots\dots (2)$$

Where:

k_g = isentropic exponent of gas in the mixture; ε = critical ratio of pressures; β = ratio of volumetric gas to liquid plus gas composition ($\beta = \frac{V_g}{V_g + V_{ld}}$).

The dependence of the discharge pressure after the FD (jump pressure, P_2) from the pressure before the jump inside of the FD (P_{bj}) is described by the following equation:

$$P_2 = k P_{bj} M^2 \dots\dots\dots (3)$$

Where:

M = Mach Number (the ratio of the flow's speed to the local sonic speed, $M = W/S$).

As one can see from Equation (2) the isentropic exponent (k) of a homogeneous two phase flow is determined by the isentropic exponent of gas in the mixture (k_g) and the ratio of volumetric gas to liquid plus gas composition (β) and does not depend on the liquid characteristics.

For the pressure jump condition the sound velocity is related to stream velocities by the following relationship:

$$S^2 = W_1 \bullet W_2 \dots\dots\dots (4)$$

Where:

W_1 = stream velocity before the jump; W_2 = stream velocity after the jump.

For the homogeneous two phase flow where the $\rho_g \ll \rho_{ld}$ the $M^2 = \frac{1}{1 - \beta}$.

The above equations indicate that when the transfer from the supersonic flow conditions to the subsonic is achieved in the jump, the compressibility of the uniform two-phase flow determined by Mach number depends only on the volumetric ratio of components in the mixture and does not depend on the properties of gas and liquid in the mixture. This result made it possible to connect pressure in the jump with the pressure before the jump and together with the obtained equation of the isentropic exponent to create a design model for those FDs in which it was necessary to obtain discharge pressure higher than the pressures of the working and injected streams.

Heat exchange between the streams in a FD occurs not in the manner as this occurs in the usual jet apparatus (JA). In JA the pressure jump in the mixed streams is associated with the condensation shock, (i.e., with the process) which is accompanied by a change in the entropy. Dr. Fisenko demonstrated that in the FDs this jump can be isentropic. In this case in the uniform (fog-like) two-phase flow the momentum exchange mechanism between the phases is based on elastic interaction of gas molecules with the finely-dispersed liquid particles and the pressure jump mode prevails over the heat exchange process.

From gas dynamics theory it is known that the temperature of gas T in any cross section of flow is proportionally (to increase of flow speed) lower than the temperature of stagnation (braking) T_o in the same flow section (Ref.9):

$$T/T_o = 1/1 + (k-1/2) M^2 \dots\dots\dots (5)$$

From equation (5) one can see that for the same gas with the increase of Mach number, the temperature T is proportionally less than T_0 . It is also known that the isentropic exponent of the two-phase mixture is always larger than the gas exponent. This means that with other equal conditions, the ratio T/T_0 in the two-phase mixture is always less than the T/T_0 for a pure gas.

Taking into account that the speed of sound in the two-phase flow is small in comparison with the single-phase (pure gas), it is possible to conclude that in a two-phase mixture the temperature ratio T/T_0 will be less than in the pure gas. This opens fundamentally new opportunities in the thermodynamics of two-phase flows.

In usual jet apparatuses, an increase in the pressure of the discharged flow occurs due to the transfer of energy of steam in the process of its condensation on the cold transported medium. At the basis of the exchange of momentum between the media lies the mechanism of viscous friction on the interphase interface. Both the process of heat exchange and the process of friction are from a molecular point of view the processes, the relaxation time of which is proportional to the mean free path of molecules.

As it was noted above, in FDs the exchange of momentum is based on the mechanism of elastic interaction of the molecules of gas (steam) with the finely-dispersed drops of liquid (with sizes of microns and even tenths of micron). The relaxation time of this process is proportional to collision frequency in the unit of time - value, which is of the order close to Avogadro's number. Naturally, this process is prevailing above processes of dissipative nature described above. The process of mixing is accompanied by a significant temperature decrease in the flow of uniform two-phase mixture. In this case the temperature of steam can become lower than the temperature of saturation of mixture, i.e., the process of the condensation of steam becomes physically impossible, and the pressure of mixture in the mixing chamber can become lower than saturation pressure of the "cold" liquid and liquid boils up.

Moreover this is not the classical evaporation of liquid from a hot surface, when the liquid in the first place leave the most “high-speed” molecules. This evaporative cooling process results in a decrease of the temperature of the remained liquid. In the FD the transfer of “cold” liquid from the state of overheating into the state of super cooling takes place abruptly as a “jump”. The liquid molecules which participate in this flashing process are of substantially wider spectrum of temperatures than in the case of surface evaporation. In the mixture flow, in which the Mach number $\gg 1$, these molecules acquire a temperature substantially smaller than its equilibrium value in the subsonic flow.

In summation, the energy supply to the mixture flow is accomplished not only by the internal energy of the working steam, but also by the internal energy of “cold” medium. In this case the process of momentum exchange occurs under conditions, when the speed of sound sharply falls, and the speed of flow and the adiabatic compressibility sharply increases. Flow becomes supersonic at the entrance into the cylindrical part of the mixing chamber. At these conditions the continuous passage through the speed of sound in the adiabatic channel of constant cross section is impossible; therefore a pressure jump takes place. Flow from the supersonic flow of fog-like structure becomes subsonic fluid flow with the finely-dispersed bubbles of overheated steam.

Under these conditions there is no sufficient time for steam condensation; therefore the collapse of steam bubbles takes place in an isentropic pressure jump. In this case a more efficient conversion of the internal energy as compared with its independent expansion takes place. Furthermore, a part of the “cold” liquid energy is also converted into work. This part of the “cold” liquid energy is transferred into the discharge work, and the braking pressure of mixture at the discharge of the FD becomes greater than the working and injected streams.

The work balance of the FD is described by the following equation:

$$\frac{k}{k-1} P_w V_w \left[\left(\frac{P_w}{P_i} \right)^{\frac{k-1}{k}} - 1 \right] = (P_d - P_i) V_w (u + 1) \dots\dots\dots (6)$$

Where:

$k = \frac{C_p}{C_v}$; C_p = specific heat at constant pressure; C_v = specific heat at constant volume;

$k = 1.3$ for superheated steam; $k = 1.13$ for dry saturated steam; w, i, d - subscript denoting the following parameters of the working, injected and discharge streams: P = pressure and V =specific volume; u = injection coefficient equal to the ratio of injected and working flow rates.

Table 1 below presents some values of discharge pressure P_d estimated in accordance with the equation (6) for different injection coefficients at the following conditions: the working superheated steam pressure $P_w=145$ psi, $T=395$ F, $V=3.36$ lb/cub ft and the injected water pressure $P_i=14.5$ psi, $T= 50$ F and $V=0.16$ lb/cub ft.

Table 1
Dependence of Discharge Pressure on the Injection Coefficient

u	20	50	100
P , psi	4,423	1,813	914

In the FDs transonic or over sonic flow of homogeneous two-phase stream is achieved by the reduction of the sonic velocity which permits to achieve the Max Number equal or higher than one ($M \geq 1$) at low stream velocities.

As the result of exchange of motion impulses between the working and injected streams, the sonic velocity in the mixing chamber is reduced. The stream at the entrance to the mixing chamber (throat) has a velocity equal or larger than the local sonic velocity. As the result of the stream deceleration the temperature and pressure at the exit of the mixing chamber increase. The pressure becomes higher than the saturation pressure at the saturation temperature of the mixture. At the specific design geometry, the discharge pressure can increase by a few times higher than the pressure of the working media. The

liquid phase in the mixing chamber has a foam type structure with a very highly turbulized surface area, therefore the dimensions of the FD are very small when compared with conventional surface type heat exchangers.

Substantial differences in the above described process take place at small injection coefficients. The reduction of the flow rate of the injected water at the constant steam flow rate leads to the increase of the water temperature to the saturation temperature corresponding to the pressure in the mixing chamber and, because of the shortage of water for condensation of all steam, the performance of the FD breaks-down. This mode determines the minimum injection coefficient. At this mode the operational and geometry factors influence the characteristics of the FD.

With the increase of the injection coefficient, when the flow rate of the injected water (as the result of the reduction of backpressure) is increased, the water temperature in the mixing chamber is reduced. At the same time, because of velocity increase in the mixing chamber, the water pressure is reduced. The increase of the flow rate of injected water leads to the reduction of the pressure at the entrance into mixing chamber up to the saturated pressure corresponding to the temperature of the heated water. Reduction of the backpressure doesn't cause the increase of the water flow rate because further pressure drop in the mixing chamber is impossible. This pressure drop which determines the flow rate of the injected water can't be increased. Further reduction of backpressure at this conditions leads to flashing (cavitation) of the water at the mixing chamber. The cavitation of water in the mixing chamber determines the maximum (limiting) injection coefficient. It should be noted that this operational condition is the working mode of the FD. This explains the important feature of the FD – the independence of the discharge flow from the back pressure at the cavitation mode.

The specific characteristics of the FD are closely related to the geometry of the mixing chamber. The discharge pressure after the FD with a cylindrical shape mixing chamber is presented by the following equation:

$$P_d = P_w \left[T_{w1} \frac{f_{w1}}{f_3} + \frac{K_1}{\varphi_3} k_w T_{wc} \lambda_{w1} \frac{f_{wc}}{f_3} - \left(1 - 0.5\varphi_3^2\right) k_w \left(\frac{2}{k_w + 1}\right)^{k_w+1/k_w-1} \frac{V_d}{V_w} \left(\frac{f_{wc}}{f_3}\right)^2 (1+u)^2 \right] + \left(1 - \frac{f_{wc}}{f_3}\right) P_i \dots\dots\dots (7)$$

Where:

$T_{w1} = P_i / P_w$; f_{w1} = cross section of the working nozzle exhaust; f_3 = cross section of the mixing chamber exhaust; K_1 = working stream velocity coefficient; φ_3 = diffuser stream velocity coefficient; $T_{wc} = P_c / P_w$ = ratio of pressure in the critical section of the working nozzle to the working pressure; λ_{w1} = ratio of the velocity of working stream at adiabatic flow to the critical velocity; f_{wc} = cross section of critical section of the working nozzle.

From this equation one can see that when the discharge cross section of the FD is equal to the cross section of mixing chamber, the discharge pressure is independent from the pressure of injected water.

The relationship between the pressure at the entrance in the mixing chamber (P_2) and the injection coefficient is determined from the following equation:

$$\frac{P_2}{P_w} = \frac{P_i}{P_w} - \frac{k_w}{2} \left(\frac{2}{k_w + 1}\right)^{k_w+1/k_w-1} \left(\frac{f_{p*}}{f_2}\right)^2 \frac{v_i}{v_w} (1+u)^2 \dots\dots\dots (8)$$

Figure 4 presents the dependence of the discharge pressure on the injection coefficient at different cross section ratios. The increase of cross section ratio leads to the increase of injection coefficient and reduction of the discharge pressure. In the FD the minimum and maximum injection coefficients are limited by the water boiling conditions in the mixing chamber. At these conditions the pressure in the mixing chamber will became lower than the saturation pressure (cavitation) at water temperature in the mixing chamber. Both these pressures at the given parameters of working steam, injected water and FD dimensions depend on the injection coefficient.

At the higher temperature of the injected water the condensation rate of working steam is less intensive than at the colder temperature. At these conditions the condensation process may not be completed at the entrance chamber and part of the mixing chamber may be occupied with noncondensed working steam. As a result the cross section area for injected water flow will be partially reduced and so the maximum injection coefficient.

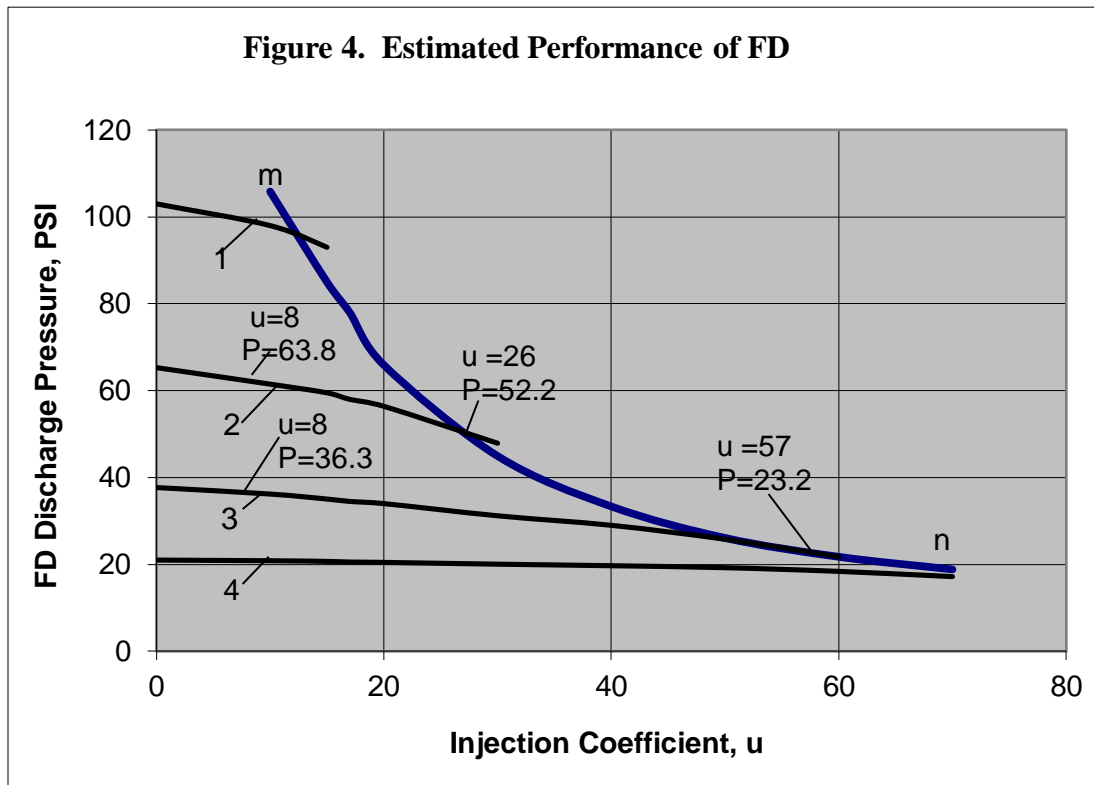

Steam Working Pressure 87 psi; Injection Pressure 11.6 psi;

1, 2, 3 and 4 – Performance Curves of the FD at Different cross section Ratios of:

1; 1.8; 4; and 10. mm Curve - Maximum Injection Coefficients.

One can see from Figure 4 that for the given conditions and the maximum injection coefficient of 57 (curve 3), the discharge pressure after the FD is 23.2 psi and the pressure increase of the injected water is 11.6 psi. At the minimum injection coefficient of 8 (curve 3), the discharge pressure after the FD is 36.3 psi and the pressure increase of the injected water is 24.7 psi. At the smaller cross section ratio the working range of injection coefficients is reduced substantially. The discharge pressure at these conditions is increasing. At the maximum injection coefficient of 26 (curve 2) the discharge pressure is

52.2 psi – pressure increase by 40.6 psi, at the minimum injection coefficient of 8 (curve 2) the discharge pressure is 63.8 psi with pressure increase by 52.2 psi. Further reduction of the cross section ratio results in reduction of difference between minimum and maximum injection coefficients and some point they became equal. At the further reduction of the cross section ratio the FD cannot be operated.

Application of Fisonic™ Devices

The FDs can be used for many heat transfer, mixing and pumping applications. Some of them are as follows:

- Replacement of surface type heat exchangers for space and district heating, power plants and various industrial applications.
- Waste heat recovery systems.
- Space cooling applications.
- Replacement of electric driven pumps.
- Deaeration processes.
- CHP applications.
- Various industrial processing and functional applications (i.e. washing, pulverization, proportioning, mixing, etc.).

Space and District Heating

Many cities in the US (New York, Boston, Philadelphia, Indianapolis) have district steam systems. For example Consolidated Edison Company of New York (Con Edison) currently serves with district steam about 1800 large customers in Manhattan. The steam pressure delivered to the customers ranges between 150 to 400 psig. The customers use the steam for space heating, domestic hot water and cooling (through steam driven or absorption chillers). Many customers currently convert the district steam into hot water in tube and shell heat exchangers. The hot water is then distributed by electrically driven pumps throughout the building for space heating and domestic hot water service. The steam condensate is

discharged into the city sewer system. The discharge of the condensate consumes a substantial capacity of the sewer system and the sewer treatment facilities. In order to reduce the temperature of the discharged stream to 150 °F the condensate is mixed with cold potable water, thus further aggravating the sewer system problems. The described system requires expensive heat exchangers (with associated maintenance cost), electrically driven pumps for hot water transport (with associated maintenance and electric cost) and substantial amounts of cold potable water. This situation results in high energy, water and sewer charges to the customers and high make-up water cost for steam generating plants.

Use of Fisonic Devices (FDs) in the buildings can improve the end-use energy efficiency and significantly reduce the environmental impact of the steam based customers. The FD heats the re-circulated building water by direct contact with steam and transports the water throughout the building, thus eliminating the tube and shell heat exchanger and the electrically driven pump. The use of the FD allows reducing the terminal temperature difference between steam and water, the required steam consumption and the amount of cold potable water. The use of the FD also enables reduced steam consumption for the chillers. The FD can be used as a pump, direct contact heat exchanger and a deaerator.

The potential market for utilization of FDs for space heating includes all buildings which convert steam into hot water. The economic motivation for the customers for buying the FD is the reduction in capital, maintenance and operating cost, as well as reduction in emission discharge to the environment.

An example of FD use for a district steam heating application is presented in Figure 5. In this application the FD replaces the surface type steam to hot water heat exchanger and the hot water electrically driven circulating pump. The space heating requirements of the building are closely related to the outdoor temperature which varies, for example for New York City, from -1F to 60F. To control the building space heat supply, the working steam flow rate throughout the FD should vary in accordance with changes of outdoor temperatures. At these conditions because of the close relationship between the thermal and hydraulic modes of the FD, the discharge pressure and the water flow rate will vary.

In order to keep the discharge water flow constant an electric driven pump is installed. The pump will operate for a limited number of hours during the year.

Figure 5. District Steam System with Fisonic Device

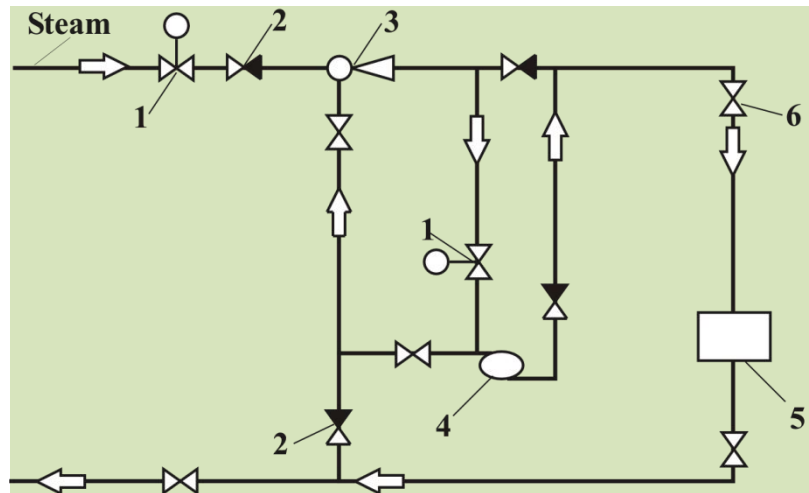

**1 – Temperature Controller; 2 – Non-return Valve; 3 – FD;
4 – Electric Driven Pump; 5 – District Heating Customer.**

The FDs can also utilize hot water as a working media. In this case it is beneficial to increase the temperature difference between the supply and return temperatures. A principal diagram of such a system is presented in Figure 6. In the central district heating plant the steam supplied from a power plant or by boilers heats the district return temperature. The heated water is supplied through a district heating system to the district customers. Each customer is equipped with a FD where the district supply water heats the building return water from 160F to 190F. About 20% of the total water flow rate circulates in the district heating system and 80% in the customer systems. Customer FDs not only heat the water but also operate as circulating pumps at the customer systems.

The potential market for utilization of FDs for space heating includes all buildings which convert steam into hot water. The economic motivation for the customers for buying the FD is the reduction in capital, maintenance and operating cost and reduction in emission discharge to the environment, along with potential waste energy recovery and utilization.

Currently officially certified small-scale manufacturers of FDs are mass producing the FDs for numerous energy conservation applications in Russia, republics of the former USSR and China. More than 200 major installation sites in Russia, the CIS and China have demonstrated a reliable and efficient operation of FDs.

Figure 6. District Steam/Hot Water System with FDs

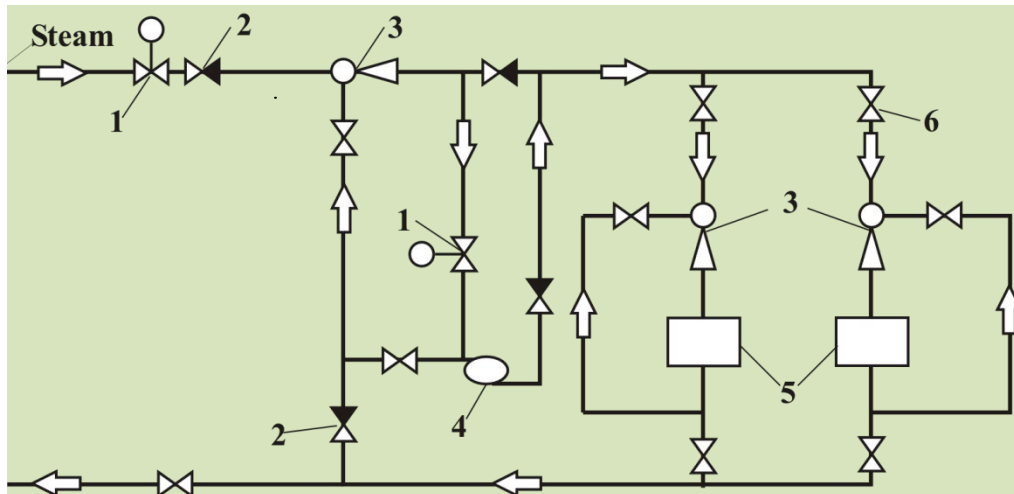

1 – Temperature Controller; 2 – Non-return Valve; 3 – FD;
4 – Pump; 5 – District Heating Customers; 6 – Valve.

Waste Heat Recovery

A diagram of waste heat recovery system with FDs is presented in Figure 7. The FD can use any available steam or hot water as a working media and increase the temperature level and pressure of the waste stream of energy.

Figure 7. Diagram of Waste Heat Recovery with a FD

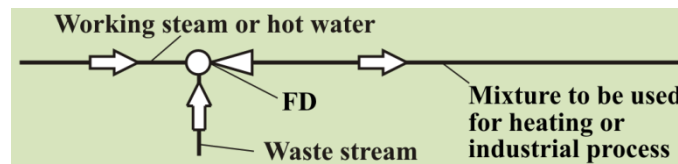

Waste Water Industry

The waste water industry consumes a large amount of energy to process waste water and with escalating costs this is becoming a big problem. As a solution to this, the industry has been very focused on capturing the methane from the effluent for use as a gas in combined heat and power plants (CHP). For some time now the industry has been investing in and improving the digester process and taking the gas to a CHP plant, the power is used at the plant or put on the grid and the heat is used in the digester process.

The waste water with the right concentration of effluent is directed into the FD and properly matched with the steam rate. The FD will break down the particles separating the gas. The gas is siphoned off and the treated hot water is discharged from the FD. The gas is fed to a properly sized CHP module which would generate electricity and heat for a self sustained cycle with the FD. The output hot treated water could be fed to an advanced heat recovery device to further generate power or heat an existing digester gas application on site.

Electric Generating Plants

The replacement of surface type feedwater heaters with direct contact heaters for improvement of cycle efficiency has been under development for many years (Ref.24). Use of FDs as direct contact heaters allows simplification of the conversion and elimination of feed water pumps. An example of application of the FD in an electric generating plant is presented in Figure 8. In this plant, surface type feed water heaters are replaced with FDs, providing direct contact heating and pumping of the feedwater.

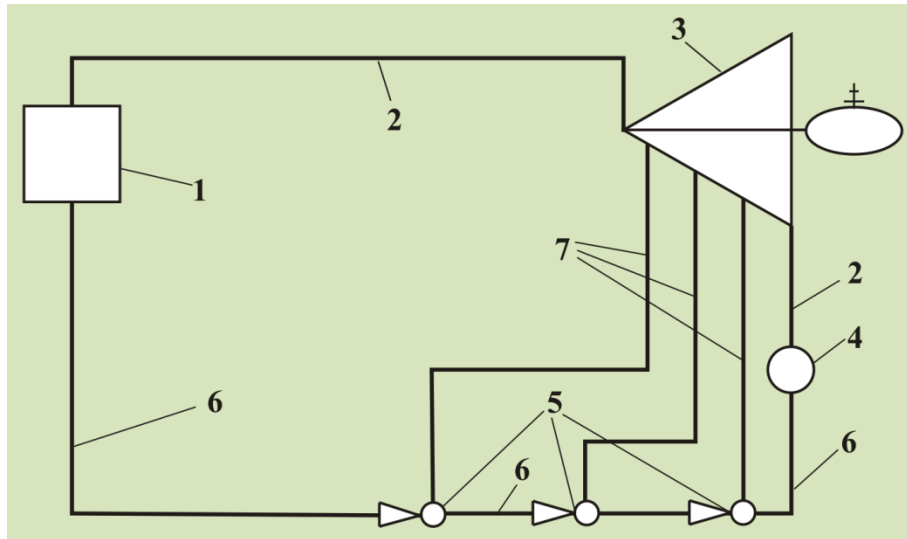
Figure 8. Diagram of a Power Plant with FDs

1 – Steam Generator; 2 – Steam; 3 – Steam-Turbine Generator; 4 – Condenser;
5 – FDs; 6 – Feed Water; 7 – Extraction Steam.

Space Cooling

The application of the FDs for space cooling is presented in Figure 9. In this system the temperature and pressure of exhaust condensate from a steam driven chiller is increased in a FD and used to generate additional space cooling in an absorption chiller.

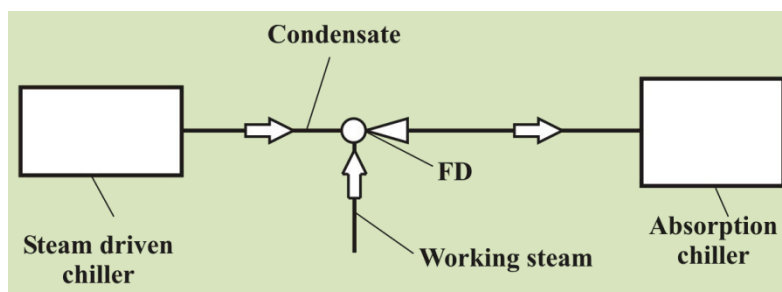
Figure 9. Space Cooling Application with FDs

Water Treatment and Deaeration

The use of the FD in the deaeration process is presented in Figure 10. In this system the FD is replacing the standard deaeration column (Ref. 25) reducing the size of the deaerator and increasing the efficiency of the deaeration process. The FD can be also used for condensing the deaerator vapor and preheating the make-up water. Applications include vacuum, atmospheric and high pressure deaerators. The system advantages include: smaller installation footprint and weight, considerably wider range of stable operational parameters, and substantial capital and operational cost reduction.

Figure 10. Deaerator with a FD

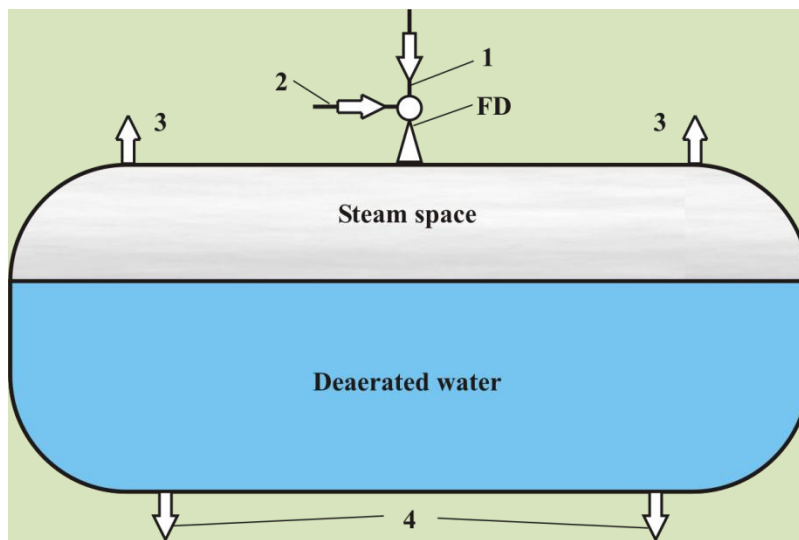

- 1 – Working Steam; 2 – Make-up Water and Condensate;**
3 – Steam Vapor with Non-condensable gases;
4 – Exit of Deaerated Water.

Food, Chemical and Other Industries

The analysis and testing have demonstrated that FDs could be efficiently used for one-step dispersion and emulsion of products for the following applications:

- Food processing industry (dairy, mayonnaise, sauces, baby food, yogurts).
- Confections (jams, syrups, condensed milk).
- Nonalcoholic beers and brews, juices and nectars, general beverages.
- Wineries (wines, wort and mash processing).
- Pharmaceuticals (ointments, liniments, solutions, synthetic blood, immersions with extracts and oils).
- Cosmetic industry (crèmes, toothpastes, makeup).
- Chemical and oil processing industries (complex chemicals, machine oils).
- Decontamination.
- Fire suppression.
- Production of ethanol and biofuels.
- Heavy oil preheating and preparation of oil-water mixtures.
- Environment cleaning facilities.
- Drying and crystallization processes.
- Petrochemical recovery, processing.
- Pulp and paper mills.
- Paint and lacquer production.
- Degasification for swimming pools (removal of chlorine and ozone).
- Carbonated beverage and sparkling wine production.

The major advantages of FDs in comparison with conventional methods include:

- Overall electricity savings of up to 3 - 5 times.
- Reduction of thermal energy consumption.
- Processing time reduced by 2 - 3 times.
- Higher product quality output due to full ultra dispersive homogenization.

- Small weight and size, low cost.
- No need for separate emulsifiers.
- Self-cleaning, low maintenance, long service cycle.
- Continuous process (rather than a batch).

Dairy Industry

In order to ensure hygienic safety and respective tolerance for dairy products, it is essential, that the pathogenic microbes are eliminated and the quantity of thermolabile microbes is reduced. Standard methods applicable to achieve the above objectives are confined to exposure to high temperatures. However, along with a positive effect in the reduction of the quantity of microbes, heat treatment results in such processes as denaturation of whey protein, formation of lactulose, fermentation, Maillard reaction, self-oxidation of lipids, vitamin deficiency, blocking of amino acids which may affect palatability (post-boiling aftertaste, etc.). Pasteurization of foodstuffs by means of direct steam injection has been used for a considerable period of time. The extensive comparison of sterilization and pasteurization of milk by conventional methods and the FDs demonstrated a number of important advantages of the Fisonic homogenization device (Ref.18, 19).

When fluid-based solids - such as vegetable matter - are added to the process flow, the FD can break down the material without any need for mechanical macerators, blades or moving parts. Furthermore, hard objects such as bone, fruit stones or other debris pass straight through without clogging or blocking.

Another feature of the FD is that the low-pressure zones within the system can be used to entrain additional liquids, gases or powders into the process fluid, thereby eliminating the need for additional pumps. If the entrained material is added upstream, it immediately becomes thoroughly mixed with the process fluid as it passes through the FD. Some substances encountered in the food processing industry are extremely aggressive. However, if appropriate materials are used in the construction of the FD or if a suitable coating or liner is employed, the device can be made impervious to hostile solutions.

The FD can handle a wide variety of liquids as well as solids in a liquid carrier.

Highly viscous media can be handled with ease and even high volumes of gravel can be pumped without causing damage to the FD. So long as the process fluid is not adversely affected by the addition of a small volume of steam condensate, the scope for use in the food industry is enormous, with real benefits available to users installing new plant or replacing existing pumps, heaters, macerators or mixers.

The FDs can be used for water saturation at various flotation, aeration and oxidation tanks at water treatment plants and at ozone saturation municipal stations.

The major advantages include: substantial savings on electric energy previously required to cool liquid to 36-37F, to make it suitable for proper carbonation, higher degree of saturation due to effective mass transfer effect, compact installation footprint, low cost and high reliability. Potential consumers include carbonated beverage manufacturers, biological treatment stations, decontamination of liquid radioactive waste.

The FDs have a perfect application for viscous liquid heating systems. They can be used for rapid steam heating of heavy oil, goudron flux oil, various chemical and foodstuff mediums contained in railroad tanks, storage tanks and other reservoirs. Advantages include: steam savings up to 70%, reduction in heating and draining time by 1.5-2 times compared with conventional systems, allow draining bottom deposits from storage tanks, produce stable fuel-water emulsion (water content 4-20%), improves fuel combustion process.

Potential consumers include: heating and power plants working on heavy fuel, steam heating and discharge stations for railroad tanks carrying viscous fuels, boiler fuel tanks and oil storage complexes, oil refineries, chemical production plants (heating of caustic water, acids), food production (heating molasses, syrups and other mediums), and efficient temperature control in various viscous material storage tanks.

The FDs can be used for non-impact hydraulic driving of reinforced concrete piles, pipes, grooved piles of all types (including standard rolled metal beams and rails).

Machine operates as a hydraulic drive, with built-in technical provisions for control cycle

automation. The major advantages: *silent operation*: can work in residential surroundings, at historic sites, does not produce vibration, will not destabilize foundations, high-speed operation, save up to 25% of piles due to precise positioning, and lossless driving, price is few times lower than conventional machines. The potential consumers include construction companies, oil and gas mining operations, road maintenance companies.

The FDs can be used for fuel mixing systems, producing ecologically clean high-octane fuels through ultrafine mixing of various grades of fuel and additives (ethanol, for example). The major advantages include: small size and weight, low power consumption, high degree of fuel homogenization producing a mixture resistant to separation, conservation of additives, precise dosing, low cost. The potential customers include: special fuels producers (high-performance racing fuels, airline fuels, and rocket fuel), fuel component storage complexes, oil processing plants.

The FDs can be used for petroleum and oil product deep refining and reforming complexes. The FDs allow petroleum reforming to obtain the maximum output of light distillates (gasoline, diesel fuel, etc) with thermal cracking, decrease crude oil viscosity level to reduce resistance of oil transportation through oil pipelines, obtain minimum sulfur level during production of ultra-low-sulfur-diesel fuel. The advantages include: 10-18% increase of light distillates output, reduction of oil viscosity level and boiling-point along with significant energy saving during cracking process, compact design not requiring modification of existing oil-processing plants..Major customers include: oil-refining plants and oil-transporting companies.

The use of FDs for decontamination processes enables high performance levels for airborne and surface decontamination processes, disinfection and detoxification, addressing the needs for personnel, transport, particle scrubbing and sensitive equipment. The FDs produce a continuous high flux super-fine droplet mist that exhibits gas-like behavior delivered with high non-uniform inherent turbulence. The major advantages include: droplet sizes are fully controllable, large arena capabilities and high mobility.

Advanced FD Developments

Recent analysis and testing of FDs resulted in a conclusion that conversion of the internal energy of overheated liquid into work can be achieved both with the presence of a “cold” heat-transfer agent and without it. Furthermore, under specific pressure values at the entrance into the FD and specific internal geometric parameters, the “cold” liquid itself becomes the two-phase medium before the pressure jump. From this phenomenon follows a principally important conclusion that under the specified conditions, the heat transfer from a less heated stream to a more heated stream becomes possible. In this case energy is not spent, but additionally useful work is obtained.

Thus, an increase of the thermal efficiency in a conversion cycle of thermal energy can be achieved not only by an increase in the temperature of heat supply T_1 , but also due to the reduction of the temperature of the heat removal T_2 lower than the ambient temperatures T .

The above described phenomenon has already become the object of practical interest of many research organizations, which are working on obtaining thermal energy from the water with the aid of different devices, some of which use electrical energy of pump drives for the generation of heat. In this case thermal energy, which exceeds the supplied energy of electric motor, is obtained. The work is already protected by a number of patents.

As it is shown by Professor the work of all similar devices is based on special features of two-phase flows described in this paper, first of all of their increased compressibility and the pressure jump feature.

The equation of energy conservation for the medium with any compressibility is:

$$dq = \left(\frac{k}{k-1}\right) P dv + \frac{1}{k-1} v * dP + dq_{mp} \dots \dots \dots (8)$$

For an incompressible fluid ($k \rightarrow \infty$, $dv=0$), that moves in the adiabatic channel, the only heat source is friction. An incompressible fluid cannot serve as working medium for the

conversion of thermal energy into mechanical work. The situation is different when the equation (8) is applied to the cross section of the flow at the border of the pressure jump, where on one side the highly compressible two-phase mixture of fog-like structure is located, and on other side of the section of the pressure jump a single-phase liquid with the small bubbles of steam (gas) is located.

The conditions of the heat balance in the pressure jump mode are:

$$\rho_{ld} (1 - \beta) \Delta q = \rho_g \beta r \dots\dots\dots (9)$$

$$\Delta q = (\rho_g / \rho_{lg}) r (M^2 - 1) \dots\dots\dots (10)$$

Where:

r = the latent heat of phase change.

From the analysis of equation (10) it is possible to make the following conclusions:

- 1) At $M < 1$, $\Delta q < 0$ – is the well known process of evaporative cooling of liquid;
- 2) At $M = 1$, $\Delta q = 0$ – is the phenomenon of degeneration of turbulences described, respectively, in reference 13 for the internal problem of a gas moving with the near-critical speed close to the exit section of cylindrical channel, and in reference 14 for the exterior problem of the flow around cylinder of the near sonic flow of gas. For the uniform two-phase mixture the problem was addressed by the Dr. Fisenko together with V. Sychikov (Ref. 7);

3) At $M > 1$, $\Delta q > 0$ – is the phenomenon, which was addressed by U. Potapov under a certain internal geometric influence on the fluid flow. Under the controlled geometric, thermal, expense or combined influence on the fluid flow the maximum possible release of thermal energy by the internal energy of liquid is described by the following equation:

$$\Delta q = (\Delta P / \rho_{ld}) (M^2 / k - 1) \dots\dots\dots (11)$$

Where:

ΔP = differential between the pressure in the jump and the back pressure of system where the generated heat is supplied;

ρ_{ld} = the density of liquid at the exit from the generator.

The experiments, carried out by Dr. Fisenko in the USA, have demonstrated that by changing the internal geometry of the FD it was possible to increase the temperature of water in the device by several degrees. In this case the heat output of the flow after FD exceeded by more than 8 times the power supplied to the electric motor.

The task, however, is of having enough time to remove the generated heat before the flow molecular bonds will be restored in the pump, and the temperature of flow is reduced. It should be noted that the power input in the FD must not be necessarily in the form of an electric motor pump.

All FDs independent of their application to the larger or smaller degree realize the effect of obtaining additional heat from the water. In this case the effect of additional generation of heat is the greater, the less the resistance of system served by the FD.

At the present time different methods of generation in the FD of heat from the water are in the stage of field experiments. In the near time the developed FDs will go in serial production.

Bench tests, in which the water is used not only as a heat-transfer agent and working medium but also as fuel, are in progress. This will allow creating devices using ordinary water as fuel for independent power supplies of thermal and electrical energy.

References

1. Fisenko, V.V. Critical two-phase flow systems, Moscow, Atomizdat, 1978.
2. Fisenko, V.V. Compressibility of Heating Medium and Effectiveness of Operation of Circulation Loops of Nuclear Reactors, Moscow, Energoatomizdat, 1987.
3. Fisenko, V.V., Some special features of the formation of gas-liquid mixtures. Journal of Physical Chemistry, 1979. №12.
4. Fisenko, V.V., On one phenomenon idea of imperfect gas. Journal of Technical Physics, 1980. V. 6.
5. Fisenko, V.V., On the boundary of inversion of the speed of sound in gases. USSR Academy of Science, Power Engineering and Transport, 1981, №4.
6. Fisenko, V.V. and Marchenko G.G., On one phenomenon idea of fluid solutions and analysis of acoustic method. Acoustics and Ultrasonic's. Kiev, Technology, 1981. №16.
7. Fisenko, V.V. and Sychikov, V.I., On the compressibility effect on the hydrodynamics of two-phase flows. Journal of Physical Engineering, 1977. V. 32, №6.
8. Fisenko, V.V., Bilder, Z.P., Ivakhnenko, I.A. and Mamalygin, U.P., Special features of two-phase flow in the long conduits. USSR Academy of Science, Power Engineering and Transport, 1982. №3.
9. Vulis, L.A., Thermodynamics of gas flows, Gosenergoizdat M, L. 1950.
10. Novozhilov, I.A. and Fisenko, V.V., New Energy Saving Technology. Journal Energetic, №3, 1996.
11. Fisenko, V.V., Fisonic Device - New Energy Saving Technology. The Journal of Industrial Power Engineering, 1999.
12. Fisenko, V.V. New Energy Conservation Technology for Space Heating and Domestic water. Teploenergetica, No.1, 2000.
13. Gukhman, A.A., Gandelsman, A.F. and Naurits, L.N., On the Hydraulic Resistance in the Supersonic Zone of Flow. Energomashinostroenie, 1957, №7.
14. Deutsch, M.E. and Philipov, G.A., Gas Dynamics of Two-Phase Media. M.: Energoizdat, 1981.

15. Fisenko, V.V., Some Principles of Theory and Practical Use of Fisonic Devices and Technologies”. Article, located on the site of the Ministry of Power Engineering of the Russian Federation. www.mte.gov.ru.
16. Gokhshteyn D.P., Kirov V.S. and Fisenko, V.V., Thermal Cycles of Nuclear Power Plants with AES with High-Temperature Reactors. Kiev. Head Publishing House of Vishchaya Shkola, 1983.
17. Fisenko, V.V., Menzel, K., and Nechvatal, J. Problematika of Nekotorych Technicheskikh Oblastnykh of Soustavakh of Centralizovannogo of Zasobovani of Teploem. Zasobovani of Teploem z of Jadernykh of Zdroju. Ceskoslovenska of komise of pro of atomovou of energii. Praha, 1988.
18. Rogenhofer, M., Hauss, E., and Fisenko, V.V., Überschallentkeimung of mit Of transsonic-eine Of vergleichsstudie of zum Of pasteur. Deutsche Of milchwirtschaft, № 10, 18 Mai 1994.
19. Rogenhofer, M., Hauss, E., and Fisenko, V.V., Aufbau of und Of wirkungsweise of einer of neuen of multifunktionalen Of überschall-Direktampf-Technologie (TRANSSONIC-Great) of für of den Of milch- of und Of lebensmittelbereich. Lebensmittelindustrie of und of milchwirtschaft, №13, 25 März 1993.
20. Fisenko, V.V. The Fisonic Energy Device. Joint Power Conference. Minneapolis, MN, October 1999.
21. Sokolov, E.Ya. and Zinger, N.M. Jet Apparatus. Energoatomizdat, Moscow, 1989.
22. Knapp, R.T., Daily, J.W. and Hammit, F.G. Cavitation, McGraw-Hill, 1970.
23. Bartlett, R.L. Steam Turbine Performance and Economics, 1958.
24. Olikier, I. Study of Feed Water Cycles with Multiple Direct Contact Heaters, Proceedings of 39th American Power Conference, Chicago, April 1977.
25. Olikier, I. “Deaeration”, Chapter 15, The ASME Handbook on Water Technology for Thermal Power Systems, 1989.